

# OIL-X IP50 ADVANTAGE

## Intermediate Pressure Filters



The removal of impurities within a compressed air system is vitally important in order to prevent contamination of downstream processes equipment and products.

Parker domnick hunter OIL-X IP50 ADVANTAGE intermediate pressure filters combine the new energy efficient OIL-X IP50 ADVANTAGE filter elements with specially designed housings to provide high efficiency filtration for applications up to 50 barg (725 psig).

Available in various filtration grades and connection sizes, they provide a level of protection tailored to your application.

### Typical Applications

- P.E.T. bottling
- Air blast circuit breakers
- Shipborne air distribution systems
- Engine starting
- Pressure testing of pipelines



### Contact Information:

**Parker Hannifin Manufacturing Limited**  
domnick hunter Filtration and Separation Division  
Dukesway, Team Valley Trading Estate  
Gateshead, Tyne and Wear  
England NE11 0PZ

**Tel: +44 (0)191 402 9000**  
**Fax: +44 (0)191 482 6296**  
**Email: [dhindsales@parker.com](mailto:dhindsales@parker.com)**  
**[www.parker.com/dhfn](http://www.parker.com/dhfn)**

### Benefits:

- Meets or exceeds the requirements for delivered air quality shown in all editions of ISO8573-1, the international standard for compressed air quality
- Coalescing filters fully tested in accordance with ISO12500-1
- Performance independently validated by Lloyds Register
- Elimination of oil, water and dirt - Available in six filtration grades
- Ideally suited for Food / Beverage / Pharmaceutical / P.E.T. applications
  - FDA Title 21 compliance
  - EC1935 - 2004 Exempt
- Trouble free, high performance - quality OIL-Xplus ADVANTAGE element backed with a 1 year performance guarantee
- 10 years guarantee on filter housing
- Ease of installation - Compact housing design
- Port options - BSPP / NPT - Weld Flange kits also available

## Filtration Grades

Filtration Grade	Filter Type	Particle removal (inc water & oil aerosols)	Max Remaining Oil Content at 21°C (70°F)	Filtration Efficiency	Change Element Every	Precede with Filtration Grade
WS	Bulk Liquid	N/A	N/A	>90%	N/A	N/A
AO	Coalescing	Down to 1 micron	0.6 mg/m <sup>3</sup> 0.5 ppm(w)	99.925%	12 months	WS (for bulk liquid)
AA	Coalescing	Down to 0.01 micron	0.01 mg/m <sup>3</sup> 0.01 ppm(w)	99.9999%	12 months	AO
AR	Dry Particulate	Down to 1 micron	N/A	99.925%	12 months	N/A
AAR	Dry Particulate	Down to 0.01 micron	N/A	99.9999%	12 months	AR
ACS	Oil Vapour Removal	N/A	0.003 mg/m <sup>3</sup> 0.003 ppm(w)	ISO8573-5	when oil vapour or odour is detected	AA

## Technical Data

Model/Grade	Maximum Operating Pressure		Minimum Operating Temperature		Maximum Operating Temperature		Initial 'Dry' Differential Pressure		Initial 'Wet' Differential Pressure			
	bar g	psi g	°C	°F	°C	°F	m bar	psi	m bar	psi		
IP50 - WS	50	725	2.0	35	100	212	N/A		70	1.0		
IP50 - AO							140	1.5	200	3.0		
IP50 - AA							N/A		N/A			
IP50 - ACS					100	212	30	86	70	1.0	N/A	
IP50 - AR									N/A		N/A	
IP50 - AAR									N/A		N/A	
									100	1.5	N/A	

\*Recommended Filter Element change:- 12 months or 6000 hours\*

\*Not applicable to Grade ACS elements. Grade ACS elements should be changed after 1000 hours operation at 21°C (70°F) or before if odours can be detected.

## Filter Selection

Model	Port Connection	L/s	m <sup>3</sup> /min	m <sup>3</sup> /h	cfm	Replacement Element Code
<input type="checkbox"/> grade IP50 010A <input type="checkbox"/> <input type="checkbox"/> <input type="checkbox"/> X	1/4"	30	1.8	108	64	K009 (Grade)
<input type="checkbox"/> grade IP50 020B <input type="checkbox"/> <input type="checkbox"/> <input type="checkbox"/> X	3/8"	45	2.7	162	95	K009 (Grade)
<input type="checkbox"/> grade IP50 030C <input type="checkbox"/> <input type="checkbox"/> <input type="checkbox"/> X	1/2"	95	5.7	342	201	K030 (Grade)
<input type="checkbox"/> grade IP50 040D <input type="checkbox"/> <input type="checkbox"/> <input type="checkbox"/> X	3/4"	145	8.7	522	307	K030 (Grade)
<input type="checkbox"/> grade IP50 050E <input type="checkbox"/> <input type="checkbox"/> <input type="checkbox"/> X	1"	285	17.1	1026	604	K145 (Grade)
<input type="checkbox"/> grade IP50 060G <input type="checkbox"/> <input type="checkbox"/> <input type="checkbox"/> X	1 1/2"	465	27.9	1674	985	K145 (Grade)
<input type="checkbox"/> grade IP50 070H <input type="checkbox"/> <input type="checkbox"/> <input type="checkbox"/> X	2"	965	57.9	3473	2044	K220 (Grade)

Note:

Connections option G = BSPP or N = NPT. Drains options F = Automatic / M = Manual.

To correctly select a filter model, the flow rate of the filter must be adjusted for the minimum operating pressure of the system.

1. Obtain the minimum operating pressure and maximum compressed air flow rate at the inlet of the filter.
2. Select the correction factor for minimum operating pressure from the CFP table (always round down e.g. for 33 bar, use 30 bar correction factor).
3. Calculate the minimum filtration capacity. Minimum Filtration Capacity = Compressed Air Flow Rate x CFP.
4. Using the minimum filtration capacity, select a filter model from the flow rate tables above. (filter selected must have a flow rate equal to or greater than the minimum filtration capacity).

## Weights and Dimensions

Model	Height (H)		Width (W)		Depth (D)		Weight	
	mm	ins	mm	ins	mm	ins	kg	lbs
<input type="checkbox"/> grade IP50 010A <input type="checkbox"/> <input type="checkbox"/> <input type="checkbox"/> X	175	6.9	78	3.1	68	2.7	1.3	2.9
<input type="checkbox"/> grade IP50 020B <input type="checkbox"/> <input type="checkbox"/> <input type="checkbox"/> X	175	6.9	78	3.1	68	2.7	1.3	2.9
<input type="checkbox"/> grade IP50 030C <input type="checkbox"/> <input type="checkbox"/> <input type="checkbox"/> X	245	9.6	89	3.5	84	3.3	2.0	4.4
<input type="checkbox"/> grade IP50 040D <input type="checkbox"/> <input type="checkbox"/> <input type="checkbox"/> X	245	9.6	89	3.5	84	3.3	2.0	4.4
<input type="checkbox"/> grade IP50 050E <input type="checkbox"/> <input type="checkbox"/> <input type="checkbox"/> X	423	16.6	122	4.8	116	4.6	5.0	11.0
<input type="checkbox"/> grade IP50 060G <input type="checkbox"/> <input type="checkbox"/> <input type="checkbox"/> X	423	16.6	122	4.8	116	4.6	5.0	11.0
<input type="checkbox"/> grade IP50 070H <input type="checkbox"/> <input type="checkbox"/> <input type="checkbox"/> X	480	18.9	170	6.7	162	6.4	10.0	22.0

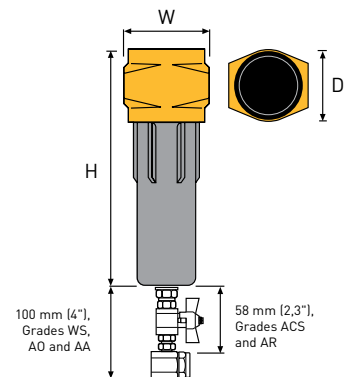

## Correction Factors

Working Pressure	bar g	20	25	30	35	40	45	50
	psi g	290	362	435	507	580	652	725
Correction Factor		2.43	1.96	1.65	1.42	1.24	1.11	1.00

Use the correction factors above for flow rates at other working pressures.

## Options:

- Flanged connection kits

IP50 Coding examples:  
AOIP50-010-AGFX  
ACSIP50-040-DGMX